

SECTION A-A

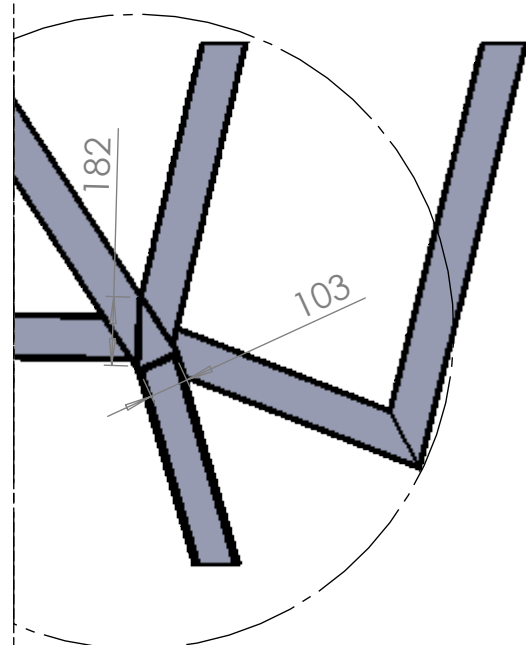

SECTION B-B

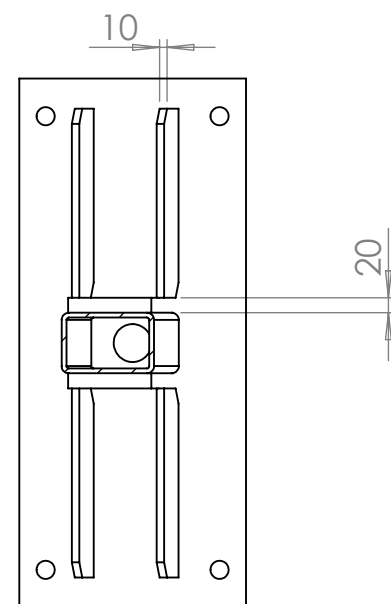

* **Verstevigingsplaten** => Volledig aflassen
 * **Poten** => volledig aflassen
 * **kokerframe** => ter plaatse van de verbindingen worden de kokers aangeschuind en vervolgens rondom afgelast. Uitzwendig worden de lassen vlakgeslepen, zodat er na het lakken geen lassen meer zichtbaar zijn.

ITEM NO.	PART NUMBER	DESCRIPTION	QTY.
1	17-1083-01	FE-37 20mm	2
2	17-1083-02	FE-37 10mm	8
3	17-1083-03	FE-37 8mm	1
4	17-1083-04	FE-37 8mm	1
5	Doos	kokerframe 150x80x6.3 & 150x80x5	1
6	17-1083-05	FE-37 20mm	2
7	17-1083-06	FE-37 20mm	2
8	17-1083-07	FE-37 8mm	1
9	17-1083-08	FE-37 8mm	1

Finish=		- Stralen - Scooperen - Primer & Natlakken - MAT ANTRECJET.	Gewicht kg	Schaal 1:50	ISO 128
Naam		Datum	Maattoleranties vlg. NEN-ISO 2768-1 Tolerantieklasse M		
M. van Dinther		15-3-2017	Benaming "Doos" Art Zuid		
Gecontroleerd			Tekening no. Samlas-Doos		
Heurkens & van Veluw B.V. Metaalindustrie		REV. 1		Sheet 1	
Hunebedstraat 2 5342 LK Oss tel. : 0412-617224 / fax : 0412-617225		Form. A2		Sheets 1	