

# JOHAN CRUIJFF ARENA 2020

Value of Design | 2018



Meint Smith  
Structural engineer  
Arcadis

# Extension AA2020

- quality improvement
- more m2
- more catering
- more restrooms
- no increase in seats



# Extension AA2020

- handover before EU Championship 2020
- 20% saving on operating costs
- 20% increase in revenue
- innovation challenge

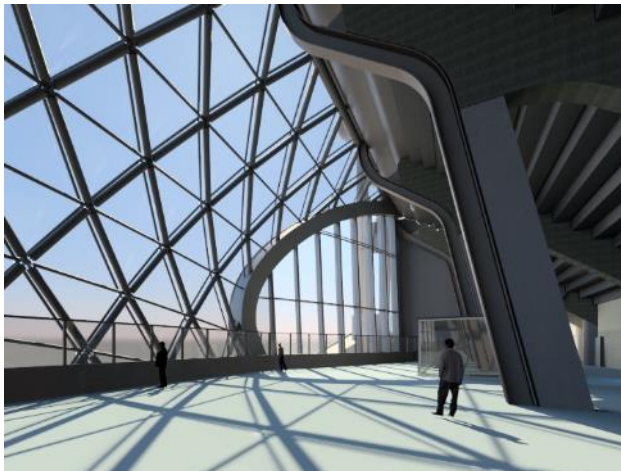

# Programme



oostzijde



noord-/ zuidzijde

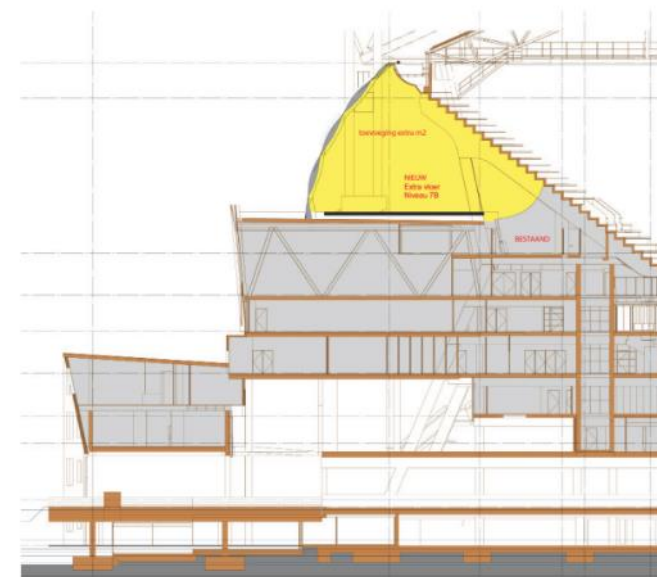

westzijde

**niveau 3**  
**niveau 4**  
**niveau 5**  
**niveau 6**  
**niveau 7**

## BVO uitbreiding fase 1

470 m<sup>2</sup>  
1200 m<sup>2</sup>  
100 m<sup>2</sup>  
1032 m<sup>2</sup>  
1370 m<sup>2</sup>

## BVO uitbreiding totaal

470 m<sup>2</sup>  
1400 m<sup>2</sup>  
100 m<sup>2</sup>  
1032 m<sup>2</sup>  
3400 m<sup>2</sup>

level  
7

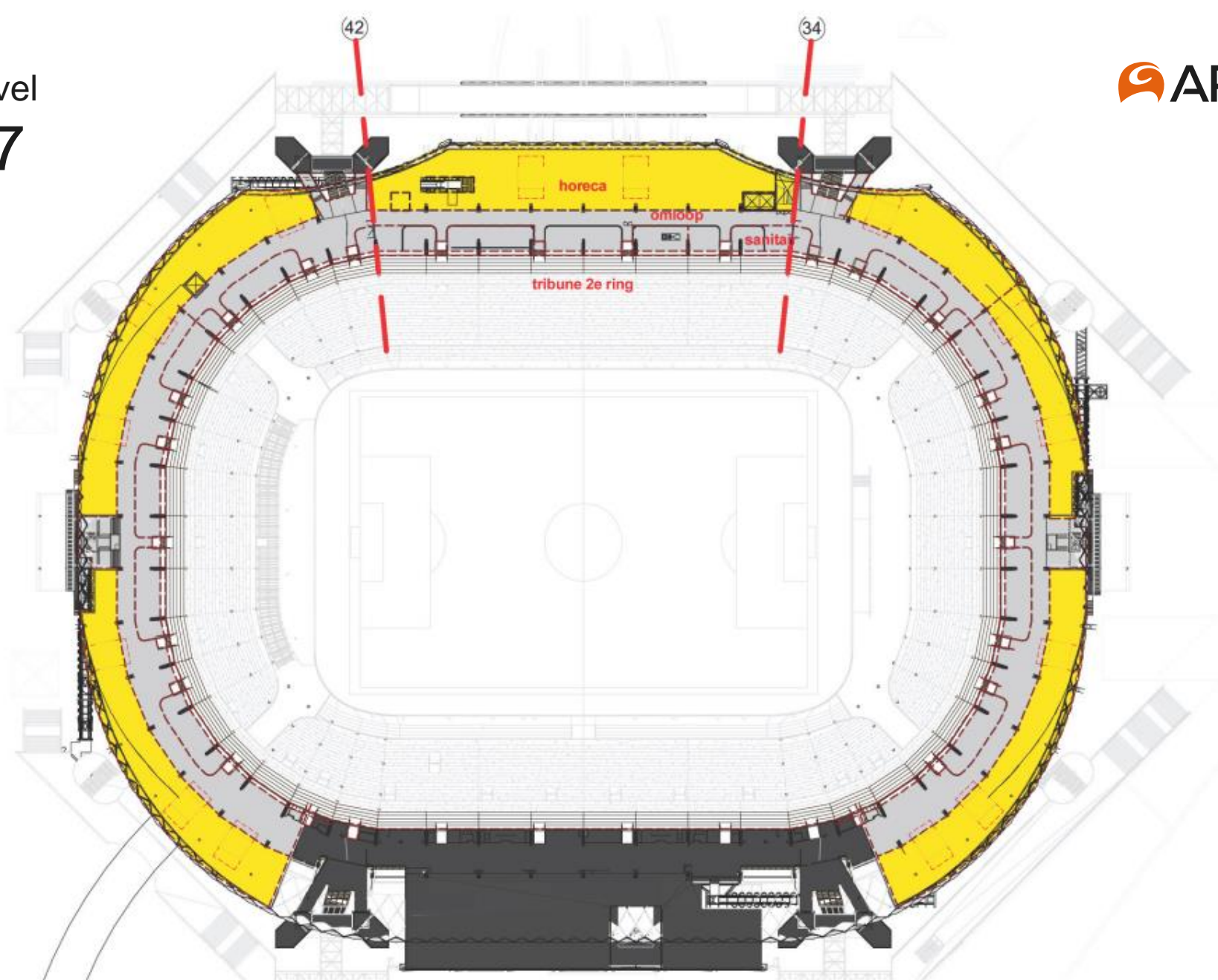

# Impression exterior



# Impression interior



Picture before project



# Design challenges



# Existing structure

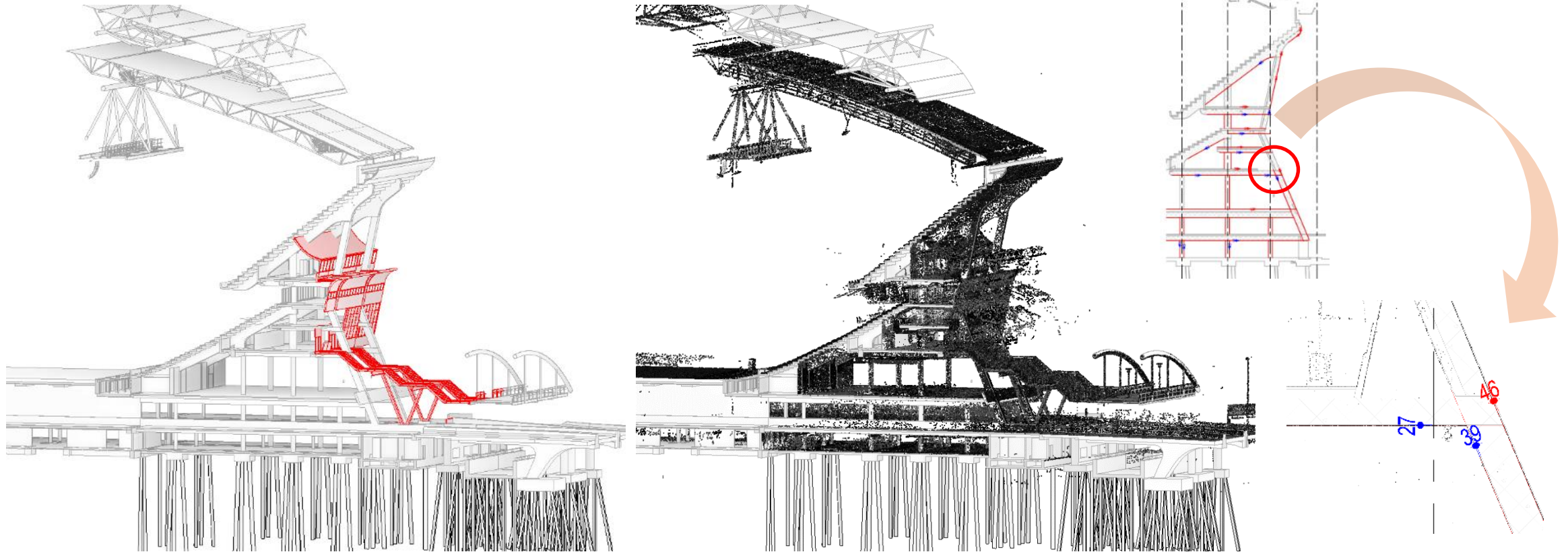

**Point cloud check to validate model and prevent clashes**

# Foundation

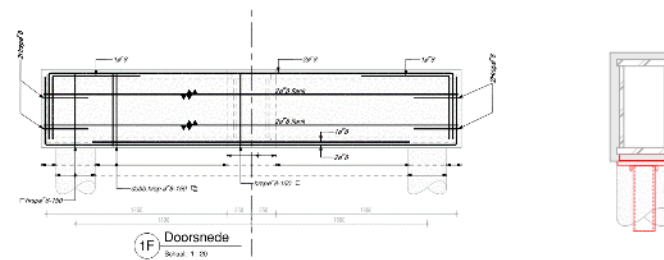
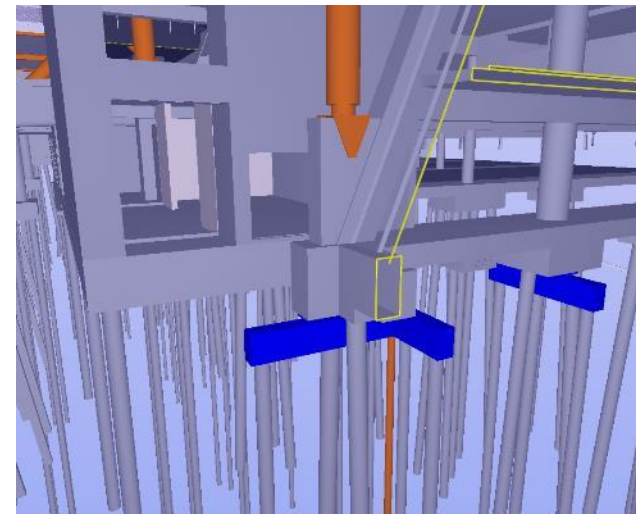
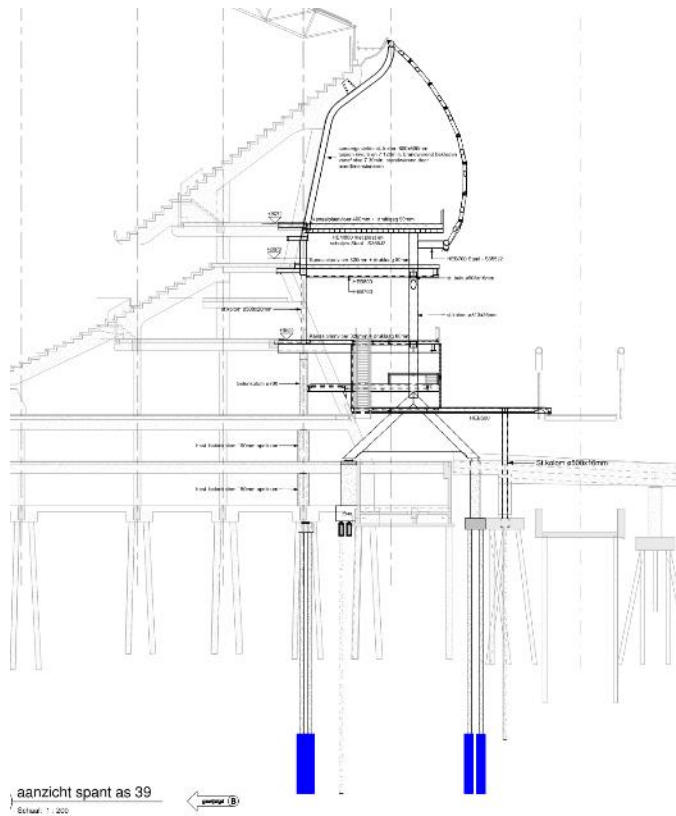

**Jetgroutpiles and hydraulic jacks on steel beams**

# Strengthening existing structure

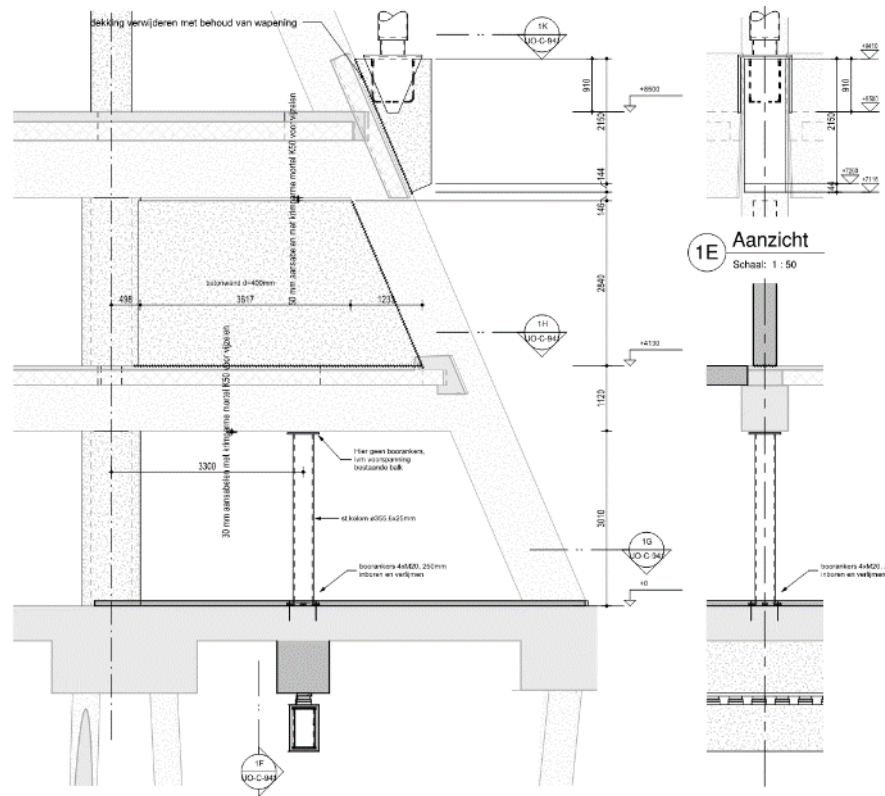

**Thickening of columns and adding diaphragm walls**

# Existing infrastructure

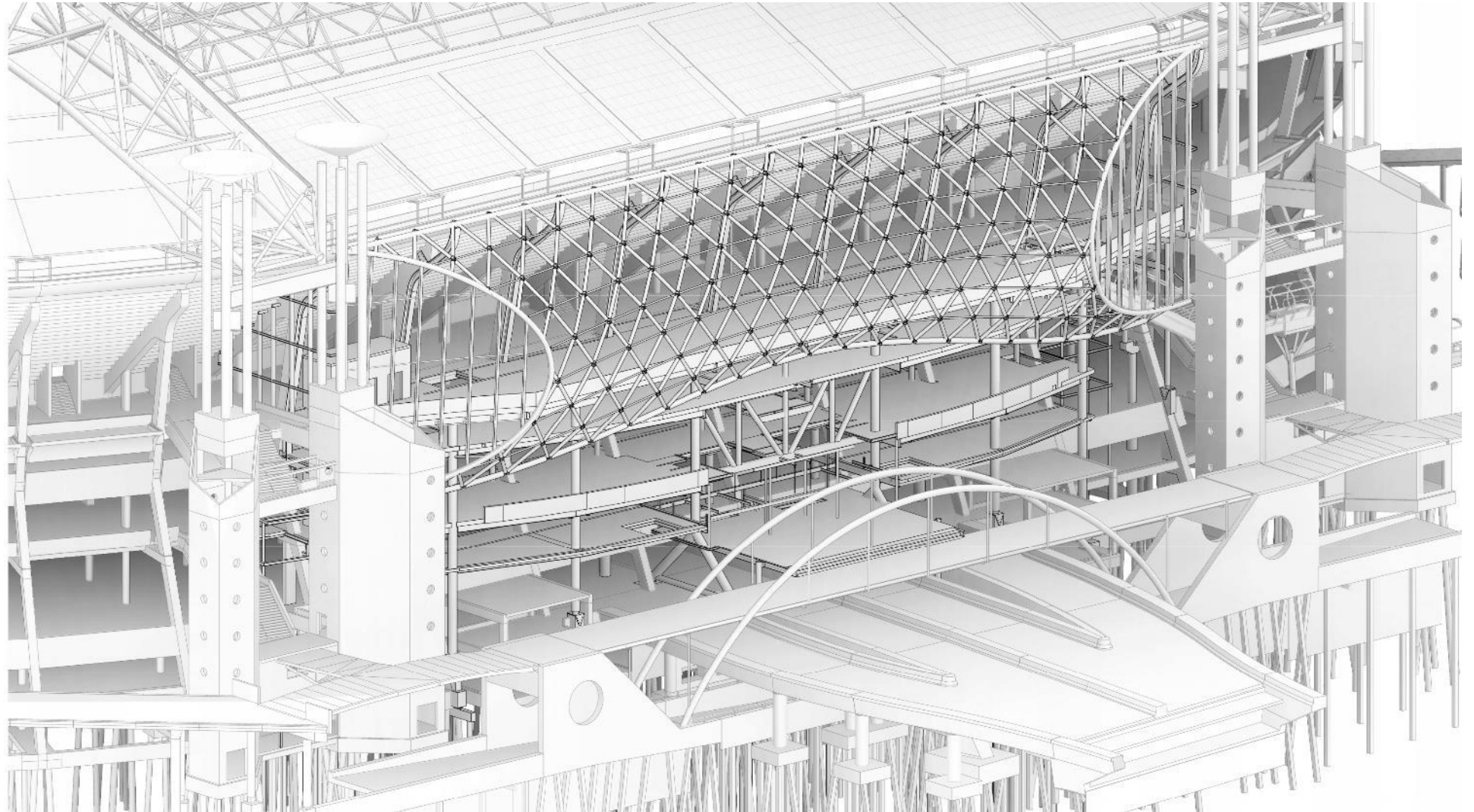
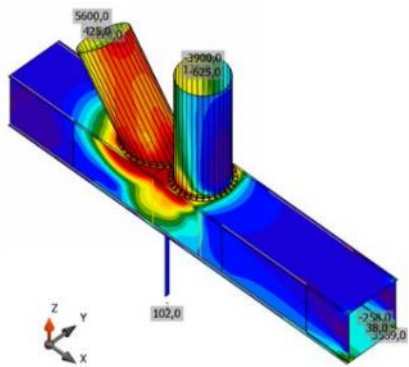
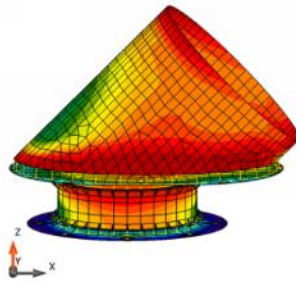

# A-frame and truss

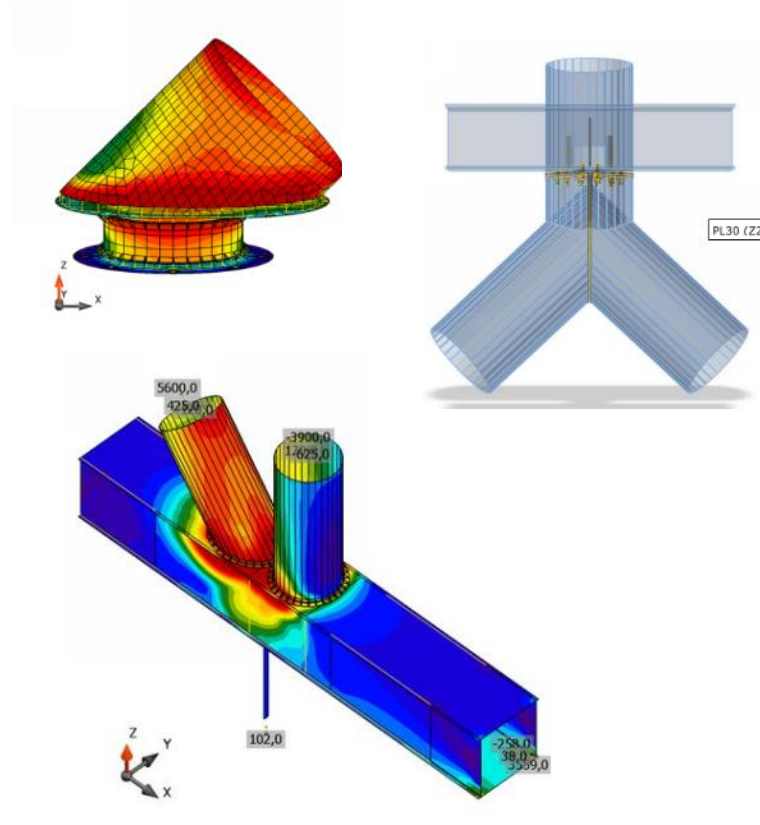
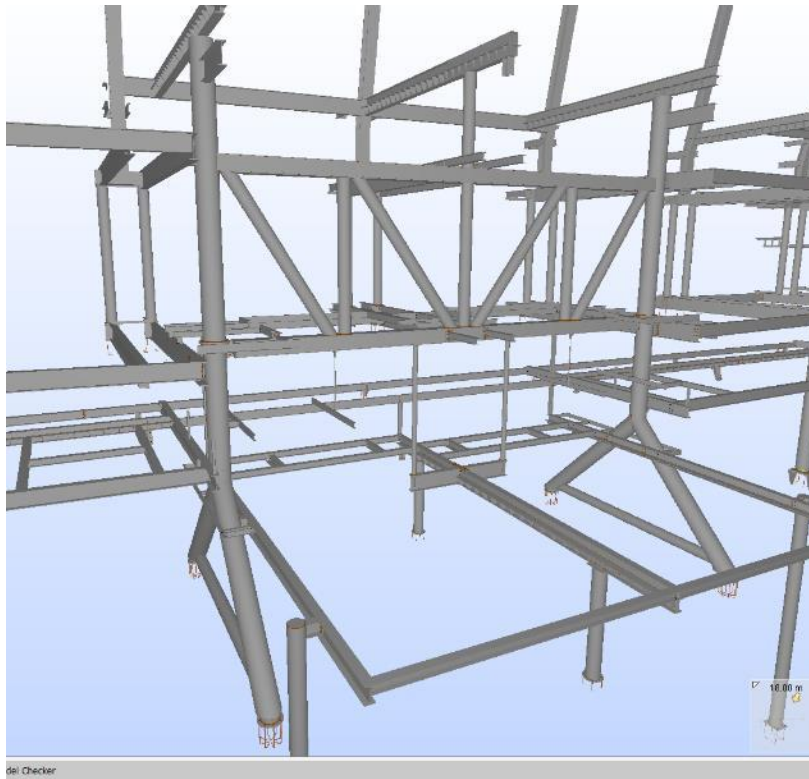

details

# Façade grid

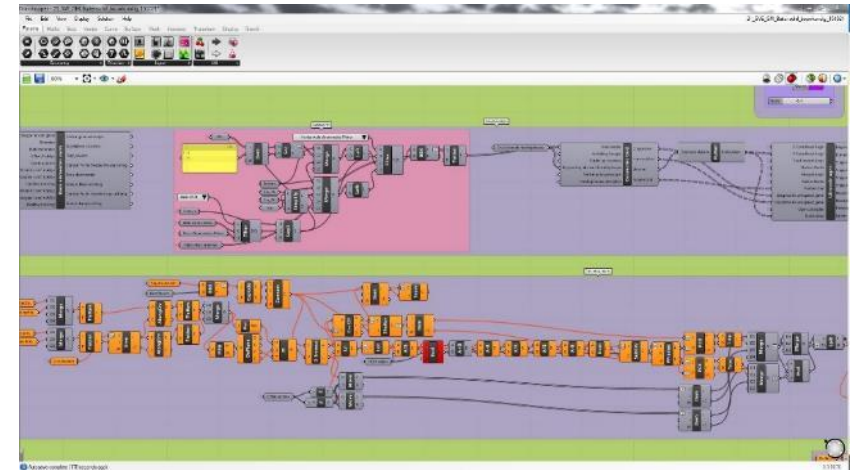
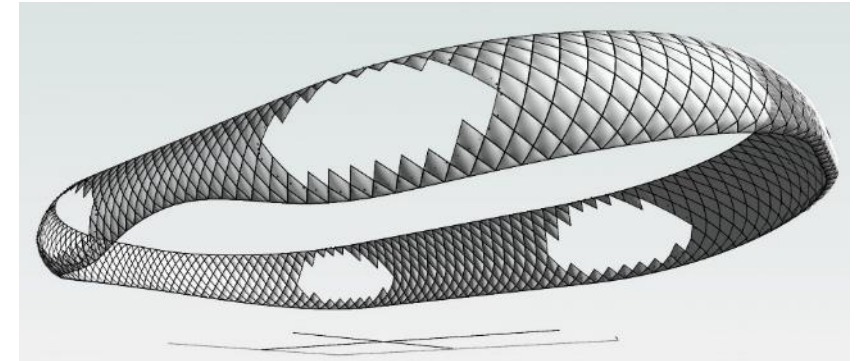
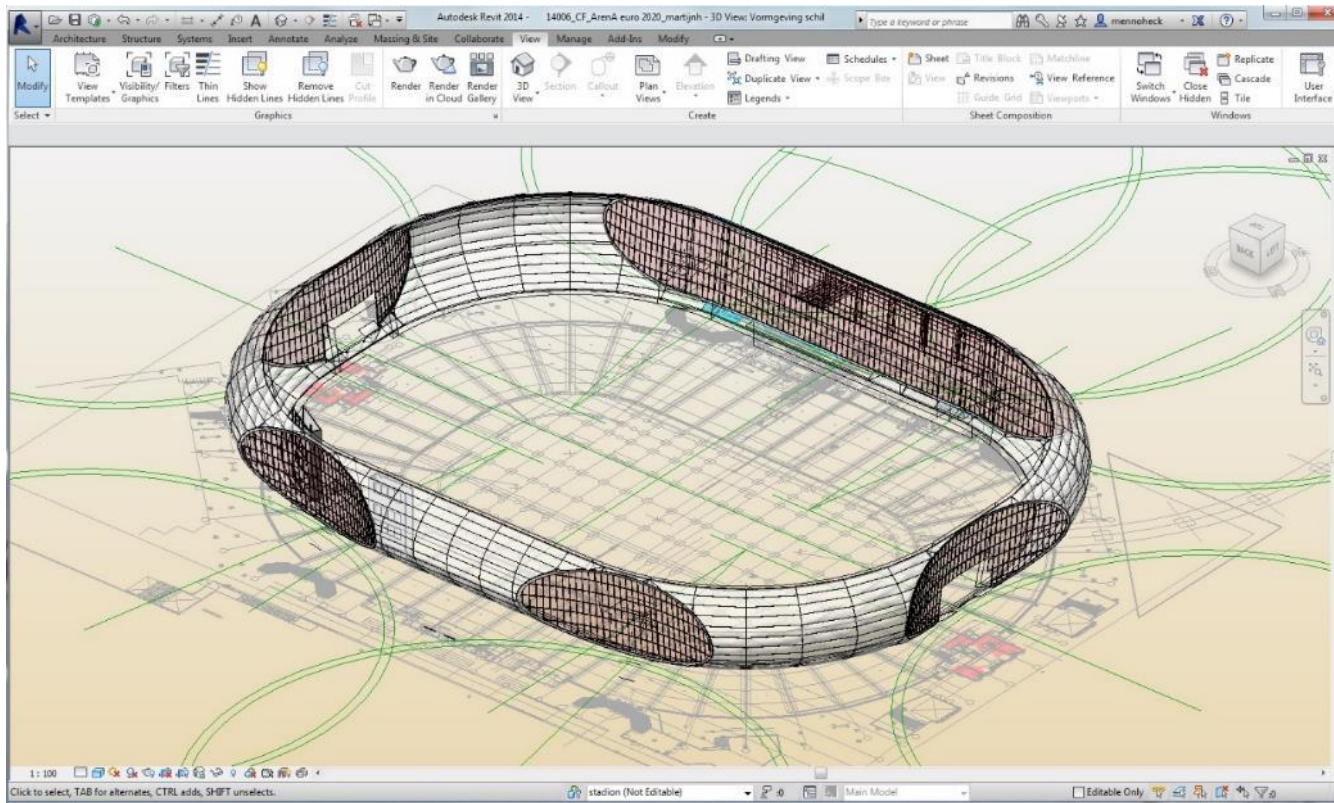

Parametric design

# Façade grid

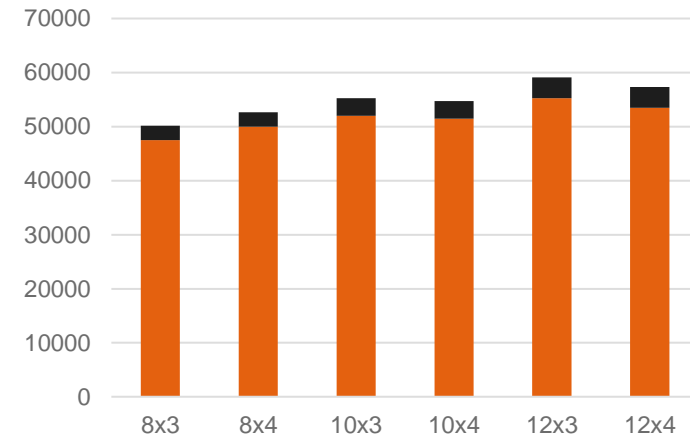
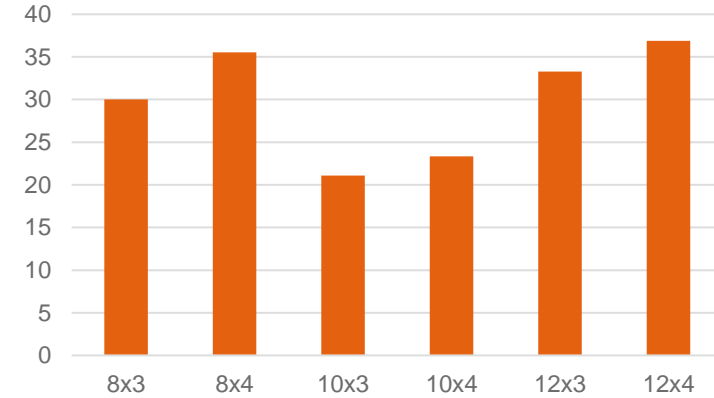
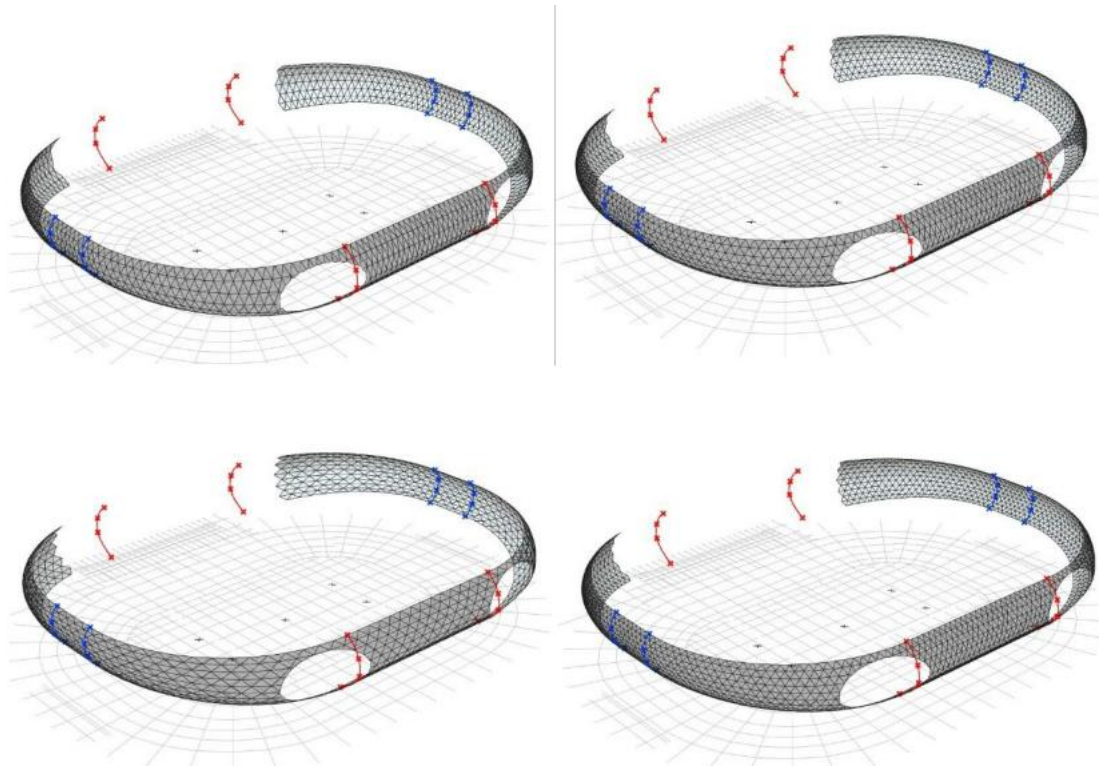

optimization

Arcadis.  
Improving quality of life.